

OPERATORS MANUAL, PART 2

1400 ZTR (Zero Turn Ride on Mower)

Table of Contents

<u>Page No</u>	<u>Topic</u>
1, 2	Table of Contents and Outline of Machine Functions.
2	Service Schedule
3	Adjustments, belt tensions, control levers.
4	Adjustments, handbrake.
5	Trouble Shooting Guide and Electrical System.
6	Removal, replacement of the mower deck.
7	Removal, replacement of the engine/ clutch assembly.
8	Removal, replacement of the hydrostatic transmission units.
9	Wiring diagram
10 - 18	Exploded view drawings and parts lists.
10	Seat and lid
11	Electrical components
12	Chassis
13	Height adjusting mechanism
14	Operators controls
15	Handbrake components
16	Engine and rear wheel drive
17	Deck assembly drawing
18	Deck assembly parts list
19	Rear discharge version – component parts.

Outline of Machine Functions

The Deutscher 1400ZTR ride on mower is fitted with a Briggs & Stratton engine or a Honda engine. Both engines use a 12v starter system with its own charging system. A key switch is used to start the engine on the control panel.

A single V belt is used to drive the transmissions from the engine. The hydrostatic transmission units have an output shaft whose speed and direction of rotation can be varied independently of the input shaft speed and rotation direction.

The output shaft of the left hand hydrostatic transmission is attached to the left rear wheel and the output shaft of the right hand hydrostatic transmission is attached to the right rear wheel. A single “fixed position” idler pulley adjacent to the engine is used to keep the drive belt tight.

The two hydrostatic transmission units are controlled by levers, as described in Part 1 of this manual, and do not turn the wheels when the levers are in their neutral position.

The front wheels of the mower are “castors” and free to pivot in any direction.

An electric clutch on the engine is used to engage the cutters via a B section belt. The clutch is switched on and off by a switch on the operators panel.

The fully floating side discharge “1400mm cut width” mower deck is suspended on four chains below the frame of the mower, and is held forward by a V shaped frame which is adjustable in length.(To tighten the deck drive belt). This ensures that the deck drive belt remains tight when the deck is raised and lowered.

The mower deck is fitted with three disc blades, and the central blade is driven by the long belt from the engine. The two outer blades are driven by separate belts from pulleys on the central blade shaft. These outer belts can be separately tensioned.

The mower deck is braced sideways with a long steel rod which can move up and down as the deck height is changed. The rod is spring loaded at the end to absorb minor collisions, by allowing the deck to swivel slightly.

Raising the mower deck is accomplished by the operator pushing on a foot pedal which in turn moves a mechanism to lift the deck. A large spring attached to the mechanism reduces the force required for the lift. The deck will descend to its lowest height by gravity once the pedal is pushed slightly and a pin is removed from the long height adjusting rod.

A lid under the operator's seat allows easy access to the battery and the fuses.

The mower is fitted with a toolbox on the left mudguard, but this can be replaced with a fuel tank as an optional extra. (This will double the fuel capacity.)

Lastly the mower has many safety features as mentioned in Part 1. These include an interlock which prevents the mower being started when the handbrake is off, an interlock which stops blade rotation when the handbrake is applied, and a seat switch which turns off the engine if you dismount and a switch under the battery lid which prevents the engine being started when the lid is raised. The handbrake is incorporated in the right hand control lever, so when the lever is moved aside to exit the seat, the handbrake is automatically applied.

Service Schedule

Component	* Frequency	Type of Maintenance
Engine cooling air screen.	100hrs	Brush clean.
Cooling Fins, engine	100hrs	Clean with air hose if available, (USE SAFETY GLASSES), otherwise by hand.
Engine air cleaner	25 hrs	Shake out dirt dry type. Wash sponge type pre-cleaner. When not serviceable, replace.
Spark plugs	100hrs	Service or replace
Fuel filter	100hrs	Replace
Battery	daily	Check water level, top up if necessary.
Hydrostatic units	10hrs or daily	Externally clean. (assists cooling)
Belts	50hrs	Check for wear and adjust.
Tyres	30hrs	Check for damage and air pressure.
Handbrake	As required	Adjust linkage. (If the mower can be pushed with the handbrake engaged.)
	10 hrs	Lubricate mechanism pivot points with light oil.
Hydro L shaped control lever.	10hrs	Lubricate pivot bolt with light oil.

* More often under extreme conditions.

Adjustments

1. Deck drive belt (From engine to mower deck)

To check the belt tension, reach in to the centre of the belt, at the rear of the mowing deck, and grasp the two sides of the belt in one hand. i.e. With your thumb around one side of the belt and your little finger(s) around the other side, Squeeze your grip to test the belt tension. You should have about 15 mm movement inwards on each side. Do not over-tighten the belt. This may reduce bearing life etc. To tighten the belt, loosen the front $\frac{3}{4}$ " UNC nut on the large thread at the front of the mower deck by a few turns. Turn the second nut on the same thread clockwise (facing forward) and with each half turn recheck the belt tension as described above. Retighten the front nut.

2. Short blade belts (On mower deck)

It is easier to tension these belts if you have the deck removed, but it can be done with the deck on the mower, and even with the belt guards in place. To tighten these belts, simply loose the 3/8" UNC nuts on the belt idler pulleys, push the pulleys inwards by hand and retighten the nuts. It may be useful to place a piece of wood behind the idler bracket when pushing it in.

Once tightened, the belt should deflect about 12-15 mm in the centre opposite the idler pulley when forced inwards by hand.

Important! The idler pulley runs on the outside of the belt. Using incorrect belts can cause premature belt failure, as not all belts are designed for this arrangement.

3. Hydrostatic transmission belt. (Under the engine)

Remove the left rear cover. (situated above the bumper bar)

To tension the belt, loosen the 8mm tensioner clamping bolt (on the left of the left engine mounting plate) by one to two turns. Push the belt idler inwards with a force of approximately 5 – 8 kg, and while holding this force, retighten the 8mm bolt.

OVERTIGHTENING THE BELT COULD CAUSE PREMATURE FAILURE OF THE HYDRO BEARINGS. THE 5 – 8 kg FORCE IS ABOUT THE MAXIMUM MOST PEOPLE CAN ACHIEVE WHEN PUSHING ON THE TENSIONER WITH THEIR THUMB. IF UNSURE OF THE FORCE REQUIRED, USE A PIECE OF FLAT WOOD AND A SPRING BALANCE. DO NOT USE A LEVER TO TIGHTEN THE BELT TENSIONER. YOU WILL VOID YOUR WARRANTY.

You can check the belt tension by pushing the belt sideways at a point halfway between the right hydro pulley and the engine pulley. The belt should deflect about 12mm when pushed sideways forcefully with your thumb.

4. Hydrostatic Transmission control levers

If the two control levers are not opposite each other, or you wish their neutral position to be further forward or backward, simply loosen the 8mm bolt (13mm spanner) at the base of each lever (facing inwards), relocate the levers and retighten the bolts.

The length of the hydro control rods inside the mower are factory set and should not need adjusting.

5. Handbrake

To test the handbrake, park the mower on a smooth level surface and put the right hand control lever in its "OUT" position. Try to push the mower with the freewheeling levers engaged. If the mower moves, adjust the handbrake as follows.

With the right lever in the "IN" position, the free play on the handbrake lever where it joins the control lever rod, should be approximately 1-2mm. (See diagram 1). If the free play is greater, tighten the nut on the handbrake rod at the base of the machine under the front of the battery, until the required free play is achieved. Recheck the handbrake operation by trying to push the mower with the brake engaged.

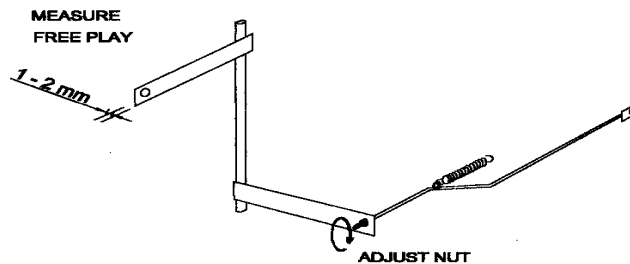

Figure 1 - Handbrake Adjustment

If the method listed above fails to improve the handbrake function, the two castellated nuts on the sides of the hydro units, at the rear, may need tightening. Please note there should still be a small amount of free play in the levers under these nuts when the handbrake is off. Remove the split pins to turn the castellated nuts, and replace the pins after winding in the nuts by hand.

6. Deck Tilt and Minimum Deck Height

If the deck is scraping on the ground at its lowest height, it can be raised at the front by relocating the "pins holding the chains on the front of the deck" further rearward in the multi-holed brackets. (the multi-holed brackets are welded to the top of the deck).

To raise the rear of the deck, remove the platform (see para 2, page 6) and then tighten the nuts on the long height adjusting rods. The nuts are on the left and right side of the mower, roughly near the height adjusting pedal and the foot support. As you tighten, periodically measure the gap between the top of the deck (at the front and the rear) and the side rails. The gap should be the same front to rear or say 10mm narrower at the rear. A slight downward slope of the blades can produce a better cut.

Finally check that the four chains are tight. If one of the chains is loose, tighten the nut on the long rod on the same side as the loose chain.

7. Removal of the Large Deck Spring

Remove the deck as described above, and the platform as described in para 2, page 6.

Slide the pedal well forward on the height adjusting rod (i.e. the rod with the multiple holes).

Grasp the height adjusting rod firmly and pull it towards the rear of the machine, at the same time removing the pin you placed behind the bracket at the right front corner of the seat. Now allow the rod to move forward slowly, until it stops.

Use a strong wire hook or sturdy rope, connected to the front of the spring, to pull the spring forward and then down off the torsion bar bracket.

Trouble-shooting Chart

Problem	Possible Cause
Mower will not start when the key is turned.	<ul style="list-style-type: none"> • Right hand lever in "IN" position. • Blown fuse in starter solenoid circuit. • Driver not sitting in the seat. • Engine/ starter motor fault. • Flat battery. (Especially if the starter solenoid clicks but the engine does not turn over) • Circuit fault. Follow circuit diagram, page 9.
Battery will not charge.	<ul style="list-style-type: none"> • Corroded or loose battery terminals. • Defective battery. • Inoperative diode or rectifier/regulator.
Battery discharges rapidly.	<ul style="list-style-type: none"> • Low water level. • Defective battery.
Engine cranks slowly	<ul style="list-style-type: none"> • Weak or discharged battery. • Corroded or loose electrical connections on the solenoid or the battery.
Blades will not turn when switched on at the panel.	<ul style="list-style-type: none"> • Right hand control in the "OUT" position. • Clutch fault. Check power is getting to the clutch before removing the clutch. • Belt missing or slipping. See "adjustments" • Circuit fault. Follow circuit diagram, page 9.
Engine will not turn off when the key is turned off.	<ul style="list-style-type: none"> • Faulty ignition switch. • Open circuit in engine earthing lead, either between the engine and key switch, or between the key switch and earth.
Engine will not turn off when leaving the seat, without turning off the ignition key.	<ul style="list-style-type: none"> • The switch under the seat is not operating when the seat lifts. • There is an open circuit in the earth wire from the engine to the switch or from the switch to the chassis earth.
Poor grass discharge from chute.	<ul style="list-style-type: none"> • Blades badly worn • Belts slipping. • Mower deck set too low for the conditions. • Driving too fast for the conditions. • Grass very wet.
Mower turning to the left or right with the control levers held opposite each other.	<ul style="list-style-type: none"> • Control levers need adjusting. See "Adjustments" • Hydro belt slipping. To check, see "Adjustments" • One or both hydro units faulty. See your mower dealer.
Mower not climbing up hills.	<ul style="list-style-type: none"> • Tyres slipping on grass. • Hydro belt slipping. • Faulty hydro units.

Electrical System Ref. Wiring Diagrams on Page 9.

1. The diode in the clutch circuit is installed to prolong switch life. FAILURE TO CONNECT THE DIODE CORRECTLY WILL CAUSE A SHORT CIRCUIT.
2. The switch connected to the right hand control lever has a second function; it prevents the mower being started unless the control lever is in the out position. This ensures the handbrake is engaged when the mower is started.
3. See page 6, Part 1. The buzzer is installed to warn operators that the battery will go flat if they leave the seat and do not turn off the ignition switch.

Deck Removal and Replacement

Removal

1. Position the mower on a level area where you wish to remove the deck, stop the engine, engage the handbrake and lower the deck to its lowest height.

2. Loosen the large $\frac{3}{4}$ " UNC nut at the front of the deck, in the centre under the front cross beam. Then loosen a similar nut at the rear of the same bracket, so the blade drive belt from the engine becomes slack. Removing the foot platform will make access to these nuts easier.

To remove the platform, pull the pin out of the height adjusting pedal and slide the pedal rearwards until it touches the control panel. Remove the four screws retaining the platform. Remove the platform by standing at the front, with your left hand in the slot through which the height adjusting mechanism protrudes and your right hand under the right edge, then lift it aside.

3. Remove the long blade drive belt from the pulley on the deck.

4. Pull out the pin securing the deck sway brace to the mower. The pin is located at the base of the chassis, just in front of the left hand wheel. Pull the sway brace bar off its support pin but leave it connected to the deck.

5. If you removed the pin from the height adjusting pedal, slide the pedal forward so it is at least 300 mm away from the control panel.

Grasp the height adjusting rod (the long square tube with the pedal on it) firmly and pull it towards the rear of the machine until the chains supporting the deck are loose. Place a bolt or the pedal pin in one of the height adjusting holes, just behind the guide bracket at the front right hand side of the seat, then slowly release your grip on the rod. The four deck chains should remain loose.

6. Pull out one of the R clips on the main deck pin at the front of the deck, and remove the pin. Lift the V frame off the deck and place a short piece of pipe or plastic tube over the front height adjusting system torsion bar and onto the belt tensioning bolt. This will hold the V frame off the deck.

7. Remove the four pins at the bottom of the chains which support the deck.

8. Release the handbrake on the mower and the 2 freewheeling levers at the rear of the mower. Grasp the front cross beam of the mower, lift the beam and walk the mower backwards over the deck.

Replacement

Replacing the deck is the reverse of the above sequence.

Engine/Clutch Removal

Removal

1. The clutch cannot be removed from the engine when it is in the in the mower, so to service the clutch or the engine, remove the engine and clutch as an assembly. The engine mounts have been cut away so this can be accomplished relatively easily.
2. Use only an approved crane or engine lifting device to lift the engine form the mower.
3. Turn off the ignition key or disconnect the battery. Release the power lead to the clutch by unplugging it on the inside of the firewall, then loosening the cable clamp. Remove all other wires leading to the engine, being careful to tag them (for ease of replacement) before they are removed.
4. Remove the covers on either side of the engine.
5. Remove the blade drive belt as described in “Deck removal and Replacement”.
6. Release the tensioner for the hydro drive belt and pull the tensioner fully backward in its slot. If this does not enable you to remove the hydro drive belt easily, remove the tensioner completely. Remove the hydro drive belt.
7. Drain the engine oil. See engine booklet.
8. Disconnect the fuel line from the engine, being careful not to spill fuel. **DO NOT SMOKE OR PERFORM THIS TASK ANYWHERE NEAR A NAKED FLAME. TURN OFF MOBILE PHONES.**
9. Remove the four engine bolts and the spacer above the strap to the clutch. Note carefully the position of the clutch strap. i.e. on the right side, with the spacer **ABOVE** the strap. The strap must be in tension with the engine running and blades driving.
10. Loosen the other end of the clutch strap and turn it in towards the crankshaft.
11. Place strong straps around the engine and, using a winch rated for the purpose, carefully raise the engine and clutch assembly. Never position yourself under the assembly once it is raised, and keep bystanders away. Lift the engine just above the rear of the mower and lock the lifting device.
12. Release the freewheeling levers on the back of the mower, and slowly draw the mower away from the engine.
13. Lower the engine carefully to the ground or bench and sit it on blocks.

Replacement

Replacement of the engine clutch assembly is the reverse of the installation. Great care must be taken to avoid damaging the clutch pulley during this operation. Don't forget to reconnect the clutch strap, and to tension the belts as described in the “Adjustments” section. Ensure no contamination gets into the fuel line, as this will end up in the carburettor.

Hydrostatic Transmission Removal/ Replacement

Removal

1. This task is a lot easier with the engine/ clutch assembly removed, the seat removed and the battery box removed. IT IS IMPERATIVE THAT THE MOWER IS ON A LEVEL SURFACE.
2. To remove the seat, disconnect the wiring under the seat, but carefully tag the wiring first. Then remove the bolt/ hinge pin on the left front corner of the seat. Slide the seat panel to the left and it will come off the right hand hinge pin.
3. To remove the battery box, first take off the battery strap, then remove the battery. Next undo the bolts on either side of the battery box, and remove the box.
4. Using a jack, mount the rear of the machine on 2 car stands positioned near the two rear corners and under the side plates.
5. Remove the two rear wheels.
6. Disconnect the pin across the rear of the machine, underneath the clutch pulley, which is connected to the handbrake levers on the rear of the hydro units. Remove the spring which is connected to the handbrake rod, on top of the chassis. Slide the handbrake rod forward.
7. Remove the springs from the ends of the freewheeling levers, then remove the levers from the hydro units. Withdraw the levers from their guides and place them aside.
8. Remove the frame (chassis) from underneath the hydro units. IF YOU PUT YOUR ARM UNDER THE MACHINE, ENSURE THE MOWER IS VERY SECURE ON THE CAR STANDS. A security block or drum under the centre of the machine is recommended.
9. The hydro units can now be removed by disconnecting and removing the bolts which hold them to the chassis side plates. If you do not have sealing plugs for the hydro units, keep the plastic tubular vent facing upwards at all times, even during removal.

Replacement

Replacement of the hydro units is the reverse of the installation. Ensure the wheel bolts are tensioned to 40ft lb, 54 Nm, and the engine bolt through the clutch is tightened to 50ft lbs, 68 Nm. Use new nyloc nuts on the hydro bolts if they have been removed more than once before. DO NOT FORGET TO RE-INSTALL THE VENT PIPES IN THE HYDRO UNITS.

Tension the blade belt and the hydro belt as specified in the "Adjustments" section.

WIRING DIAGRAM – BRIGGS and STRATTON ENGINE

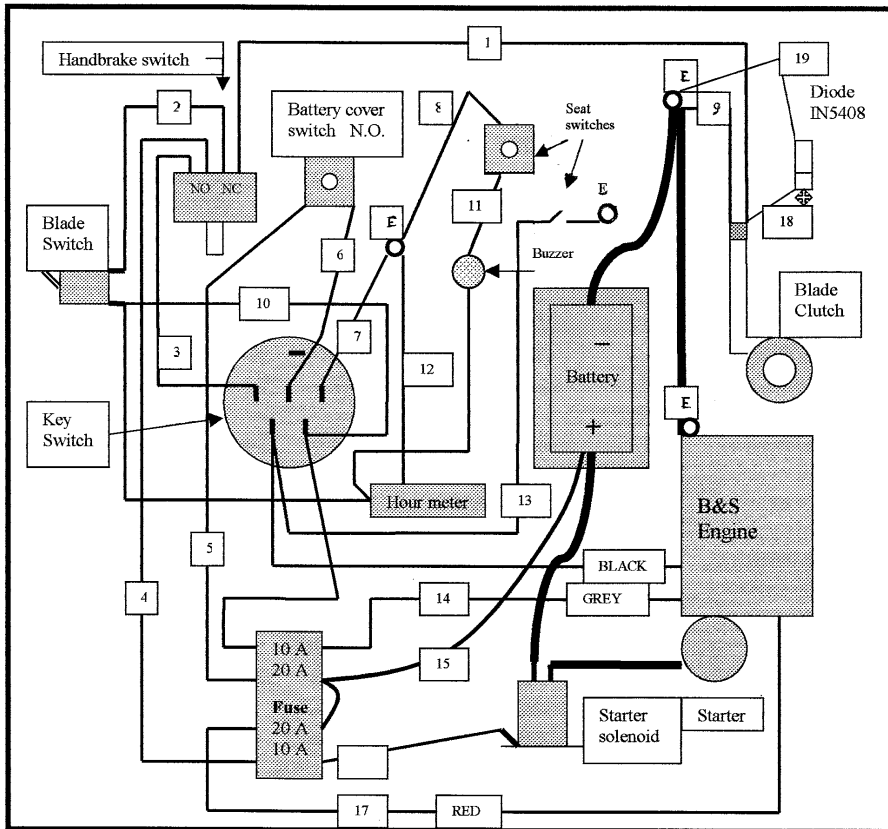

Wire No. / end fitting/ length mms, colour / end fitting

- 1 FS (870,yellow)MS (50 , yel.) B – diode - B (100, yellow) O
- 2 FS (510, yellow) FS
- 3 FS (300, blue) FS
- 4 FS (770 , blue) FS
- 5 FS (630,red) FS
- 6 FS (820,red) FS
- 7 FS (280,green) O
- 8 O (500,green) FS (80,green) FS
- 9 O (110,green) MS
- 10 FS (600,gre) FS (160, yellow) - FS (430,yellow) FS (540,red) B
- 11 FS (300,black) B
- 12 FS (490, green) O
- 13 FS (650,black) FS (760, black) MP
- 14 FS (120, grey) FR
- 15 FS (50,red) FS (300,red) O
- 16 FS (110,blue) FS
- 17 FS (110, red) FR

Wires 1 – 17 are pvc coated, 2.2mm diameter.

End fittings = FS (1/4" female spade), MS (1/4" male spade), O (1/4" round hole), FR (4mm female round socket), MP (4mm male round pin), B (bare end, 15mm wire)

WIRING DIAGRAM – HONDA ENGINE

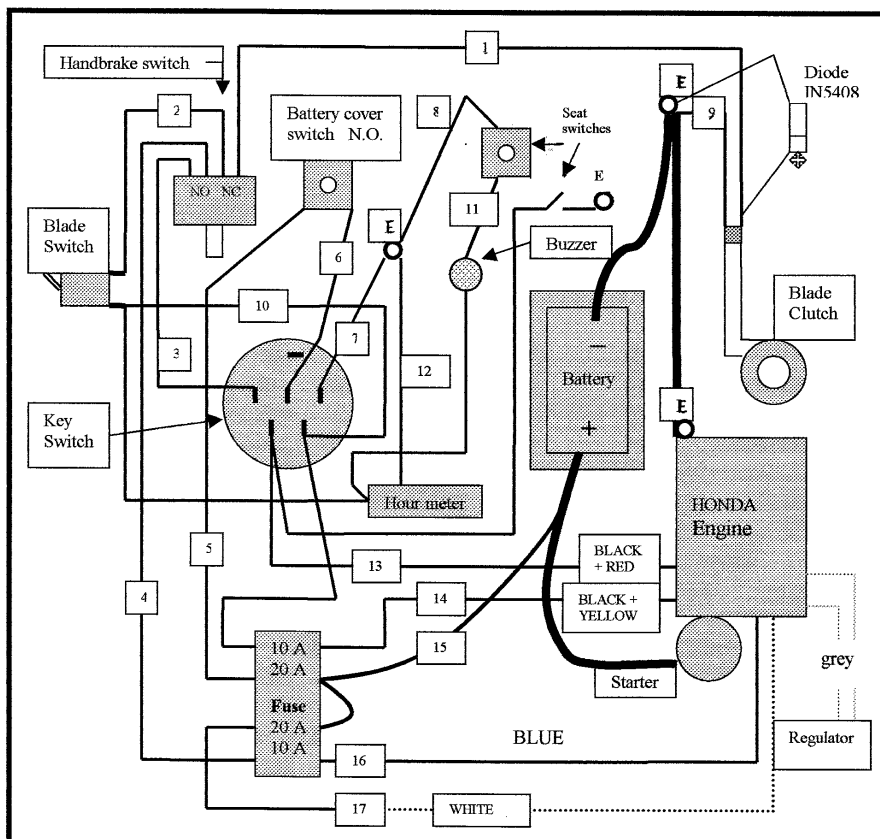

Wire No. / end fitting/ length mms, colour / end fitting

- 1 FS (870,yellow)MS (50 , yel) B – diode- B (100, yellow) O
- 2 FS (510, yellow) FS
- 3 FS (300, blue) FS
- 4 FS (770 , blue) FS
- 5 FS (630,red) FS
- 6 FS (820,red) FS
- 7 FS (280,green) O
- 8 O (500,green) FS (80,green) FS
- 9 O (110,green) MS
- 10 FS (600,gre) FS (160, yellow) - FS (430,yellow) FS (540,red) B
- 11 FS (300,black) B
- 12 FS (490, green) O
- 13 FS (650,black) FS (760, black) MP
- 14 FS (120, grey) FR
- 15 FS (50,red) FS (300,red) O
- 16 FS (300, blue) FS
- 17 FS (110,red) FR

Wires 1 – 17 are pvc coated, 2.2mm diameter.

PARTS LISTS

SEAT and LID

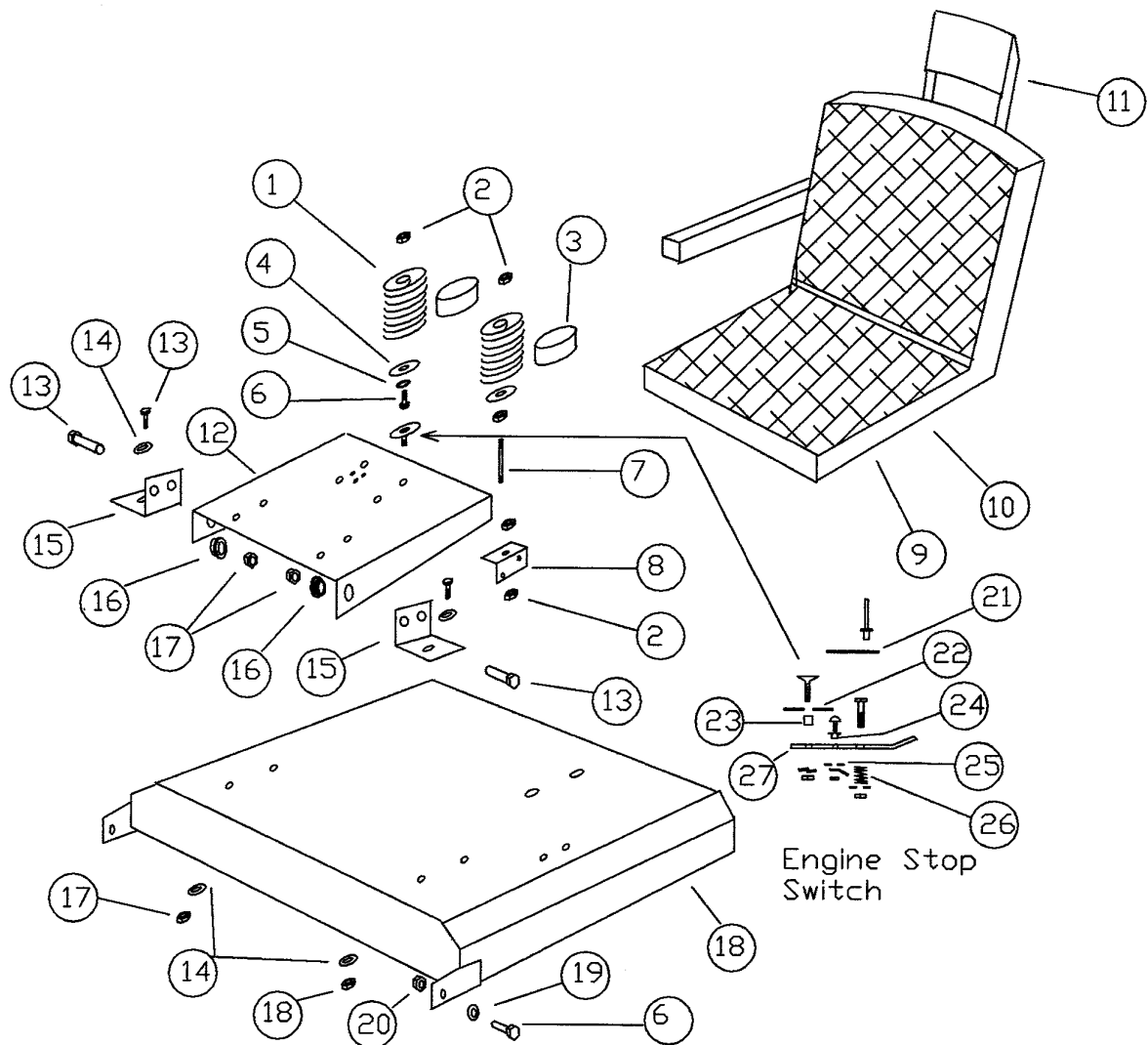

Item No	Part No	Part Description	Item No	Part No	Part Description
1	1394	Seat spring (was T535)	15	1818	Seat hinge bracket
2	1072	Nut 8mm	16	1063	Bush – seat pivot
3	1407	Plastic cap, spring (was T536)	17	1062	Nut, 3/8' UNC nyloc
4	1019	Washer 8 x 20	18	1054	Seat lid assembly
5	1018	Spring washer 8mm	19	1019	Washer 8 x 20
6	1017	Bolt M8 x 20	20	1099	Nut 8mm nyloc
7	1040	Seat switch stud	21	1816	Earthing strap
8	1817	Micro switch bracket	22	1821	Washer 50 Dia
9	1330	Standard seat, KAB P2	23	1815	Engine cut out spacer
10	1371	Deluxe seat, KAB U2	24	1945	Nylon insulator
11	1372	Back rest, KAB P2 seat	25	1946	Nylon washer
12	1819	Seat base plate	26	R87	Spring, Standard seat
13	1058	Bolt 3/8" UNC x 1"	27	1132	Spring, deluxe seat
14	1059	Washer 3/8" x 1"		1814	Engine cut out plate

ELECTRICAL COMPONENTS

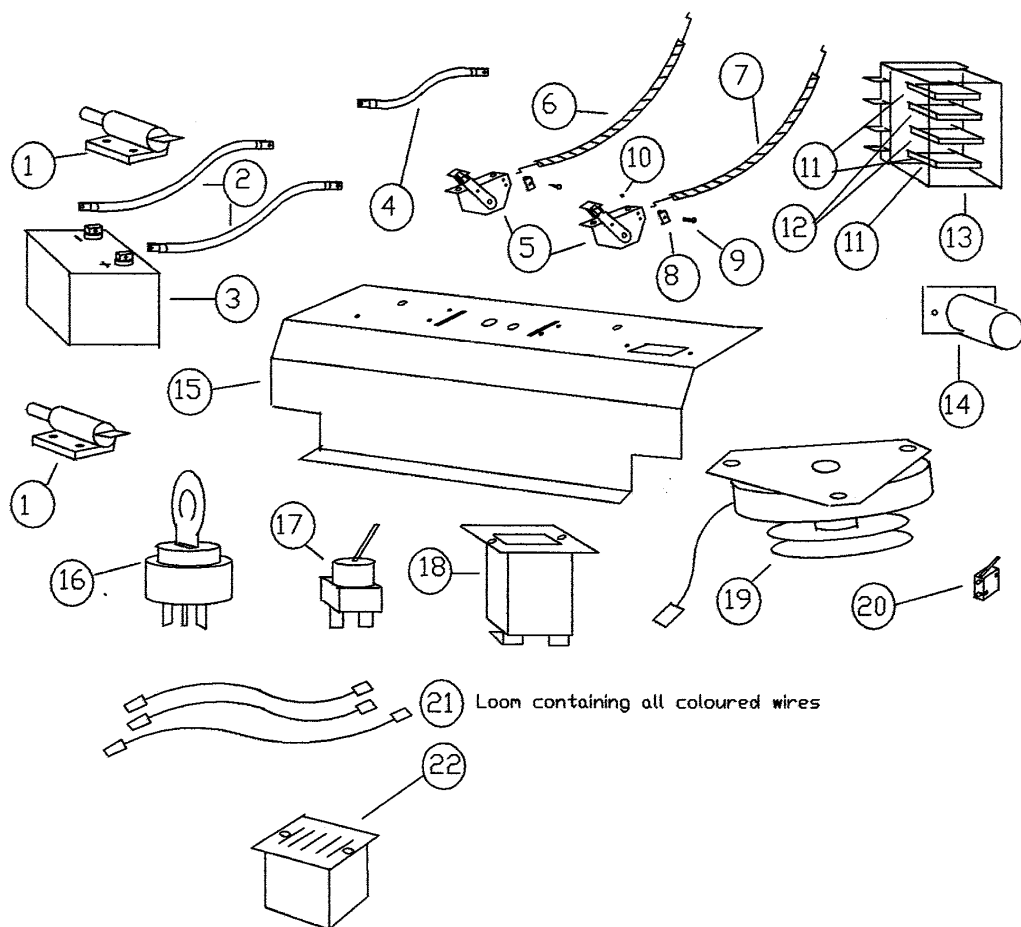

Item No	Part No	Part Description	Item No	Part No	Part Description
1	1263	Lid & handbrake switch	14	1255	Starter solenoid (B&S only)
2	1373	Battery cable (was R313)	15	1135	Control panel
3	1374	Battery (was T315)	16	1261	Key switch
4	1375	Engine earth lead.	17	1262	Blade switch
5	1396	Throttle plate assembly - B&S	18	1256	Hour meter
6	1397	Choke cable assembly - B&S	19	1333	Electric clutch
	1810	Choke cable assembly - Honda	20	1947	Micro switch
7	1398	Throttle cable assembly - B&S	21	1250	Wiring loom, incl. buzzer
	1811	Throttle cable assembly- Honda	22	1712	Buzzer
8	1154	Cable clamp			
9	1259	Screw 5mm x 15			
10	1260	Nut 5mm, nyloc			
11	1254	Fuse 10 amp (2 off)			
12	1253	Fuse 20 amp (2 off)			
13	1252	Fuse box			

CHASSIS

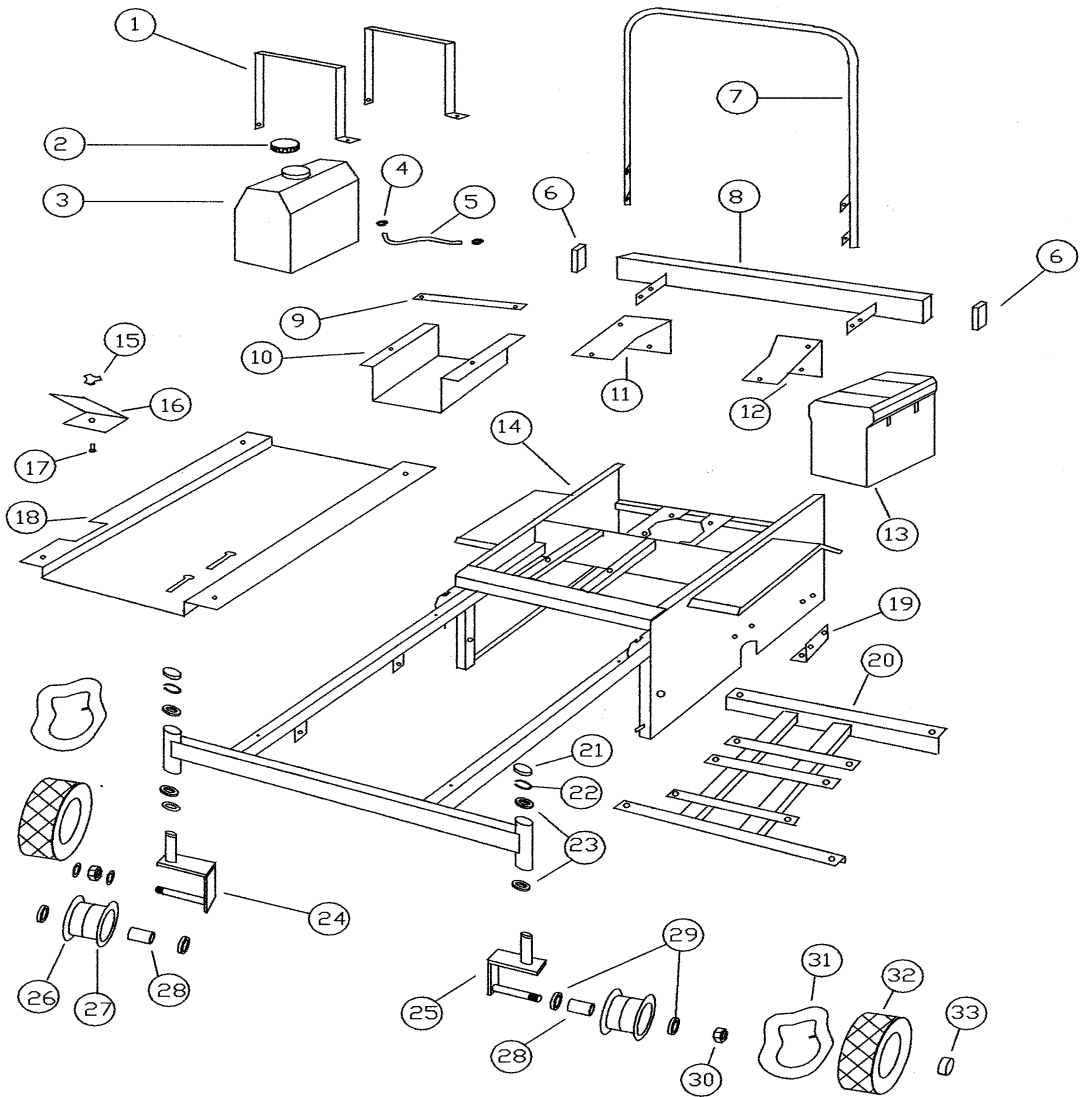

Item No	Part No	Part Description	Item No	Part No	Part Description
1	1187	Tank strap (2 off)	18	1136	Platform assembly
2	1329	Tank cap	19	1072	Hydro support bracket
3	1393	Fuel tank including inlet fitting	20	1064	Sub frame
4	1399	Hose clamp	21	1191	Bearing cap
5	1364	Tank outlet hose	22	1198	Circlip
6	1311	Bumper bar plug (2 off)	23	1199	Bearing (6205-2RS)
7	1373	Roll over protection bar assy. (optional extra)	24	1192	Kingpin assembly RH
8	1129	Bumper bar assembly	25	1193	Kingpin assembly LH
9	1120	Battery clamp	26	1356	Outside rim, front wheel
10	1119	Battery box	27	1357	Inside rim, front wheel
11	1004	Engine cover RH	28	1201	Bearing spacer
12	1003	Engine cover LH	29	1200	Front wheel bearing (6203-2RS) (Two per wheel.)
13	1308	Toolbox	30	1202	Wheel nut
14	1376	Chassis assembly	31	1353	Tube, front wheel
15	1145	Plastic knob	32	1354	Tyre, front wheel
16	1140	Footrest plate	-	1760	Complete front wheel including tyre and tube.
17	1143	Coach bolt	33	1231	Wheel bearing cap (was R100)

HEIGHT ADJUSTING MECHANISM

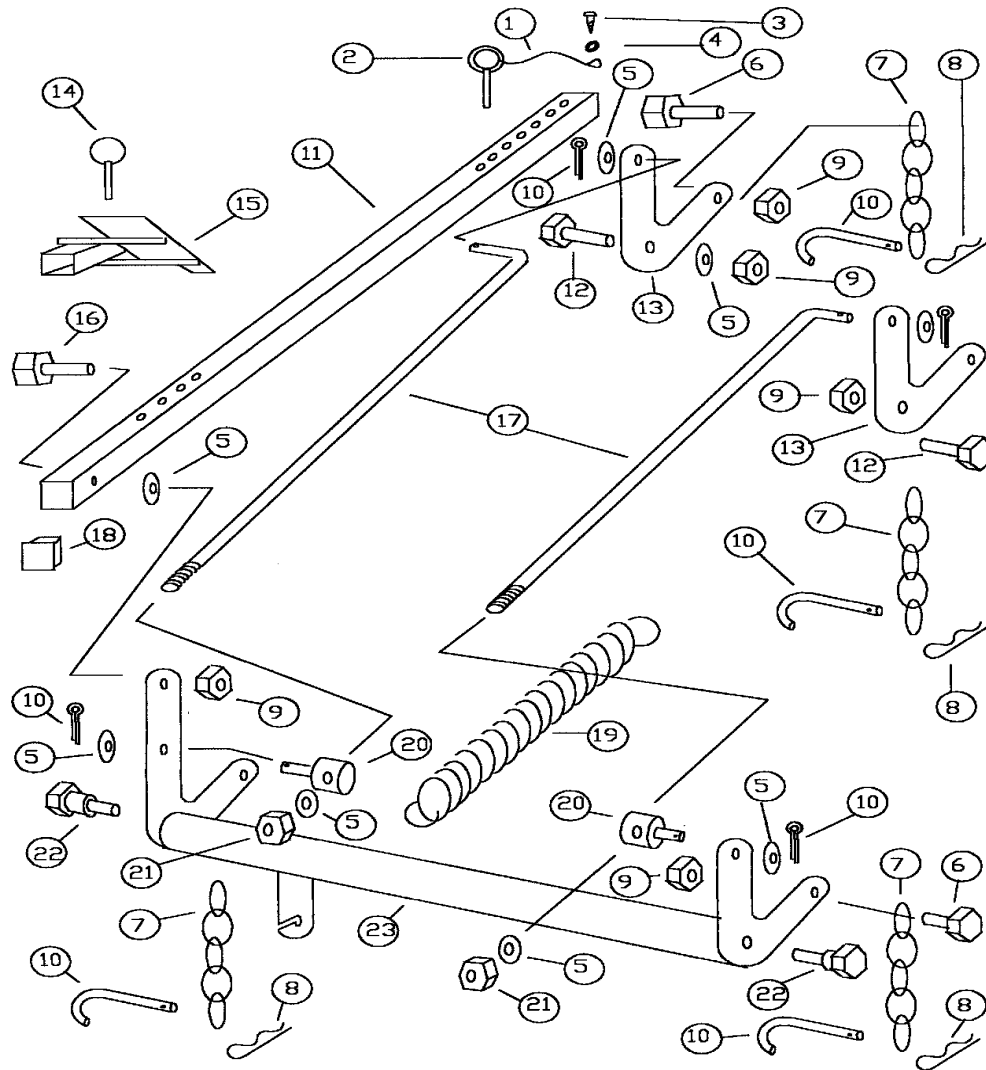

Item No	Part No	Part Description	Item No	Part No	Part Description
1	1358	Cable, height adjusting pin	13	1159	Lift lever, rear deck
2	1276	Height adjusting pin	14	1183	Pedal pin
3	1153	Self tapping screw	15	1178	Pedal assembly
4	1378	Washer 3/16"	16	1379	Bolt 3/8" Whit x 3"
5	1059	Plain washer 3/8" ID	17	1174	Height adjusting rod
6	1436	Bolt, 3/8" Whit x 1"	18	1359	Plastic plug
7	1167	Chain, 5 links	19	1166	Spring, deck lift
8	1171	R clip	20	1175	Height adjusting swivel
9	1168	Nyloc nut 3/8" UNC	21	1177	Nyloc nut 3/8" UNC
10	1172	Deck pin	22	1053	Stepped bolt
11	1173	Height adjusting tube	23	1160	Torsion tube assembly
12	1437	Bolt, 3/8" Whit x 2"			

OPERATOR'S CONTROLS

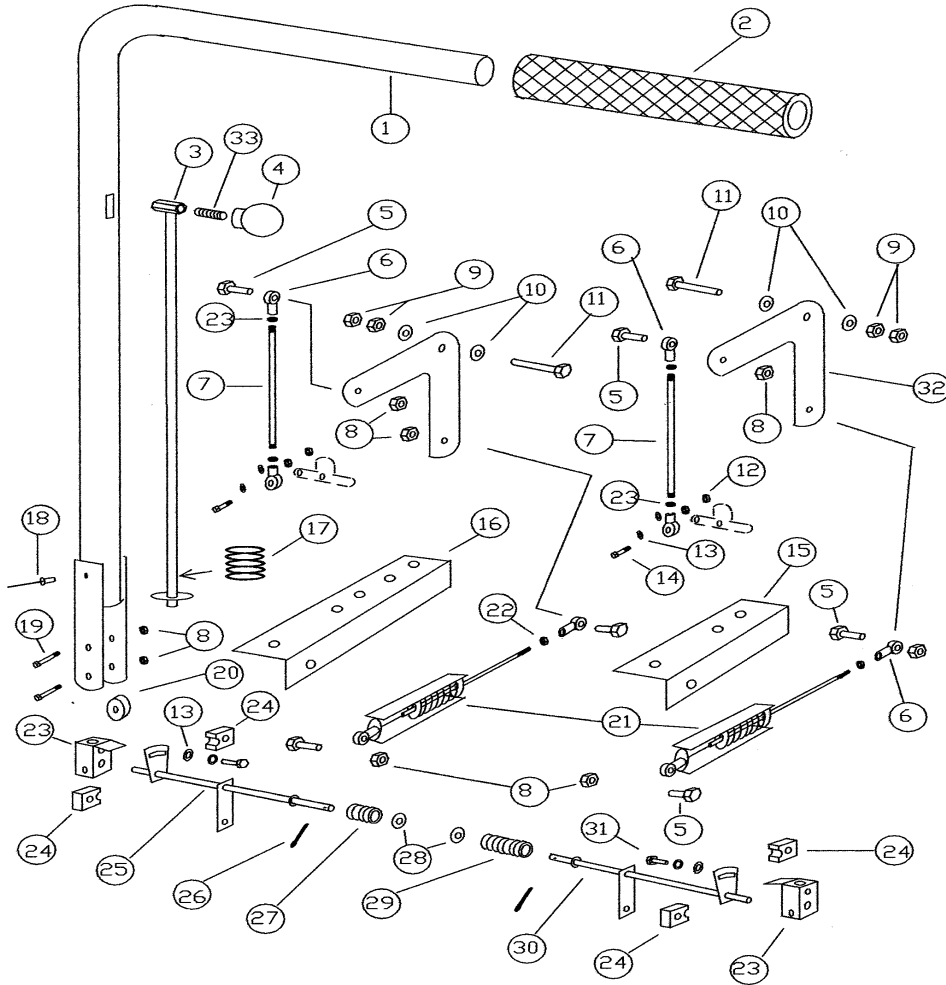

Item No	Part No	Part Description	Item No	Part No	Part Description
1	1106	Control lever assembly, L&RH (Includes items 2,3,4, 17 & 18.)	19	1118	Bolt M8 x 40
2	1114	Handgrip set	20	1117	Nylon roller
3	1109	Release assembly	21	1404	Over-travel device - assembly
4	1112	Plastic knob	22	1102	Nut 5/16" UNF
5	1098	Bolt M8 x 30	23	1073	Pivot block assembly
6	1103	Rose joint , 5/16" UNF	24	1085	Nylon bearing half (2 each side)
7	1091	Vertical rod, hydro control	25	1076	RH control assembly
8	1099	Nyloc nut M8	26	1314	Split pin
9	1417	Nut 10 mm	27	1132	Spring RH control
10	1059	Washer 3/8" x 1"	28	1344	5/8" x 1" washer
11	1416	Bolt M10 x 40	29	1133	Spring, LH control
12	1072	Nut M8	30	1096	LH control assembly
13	1019	Washer 8 x 20	31	1342	Bolt M8 x 25
14	1328	Bolt M8 x 50	32	1088	Right angled lever (2 off)
15	1097	Support, RH control	5002	5002	Bronze bush (not shown, fits in lever No 32.)
16	1081	Support, LH control	33	1093	1/4" W threaded rod
17	1113	Spring, release assembly			
18	1116	Pop rivet			

HANDBRAKE COMPONENTS

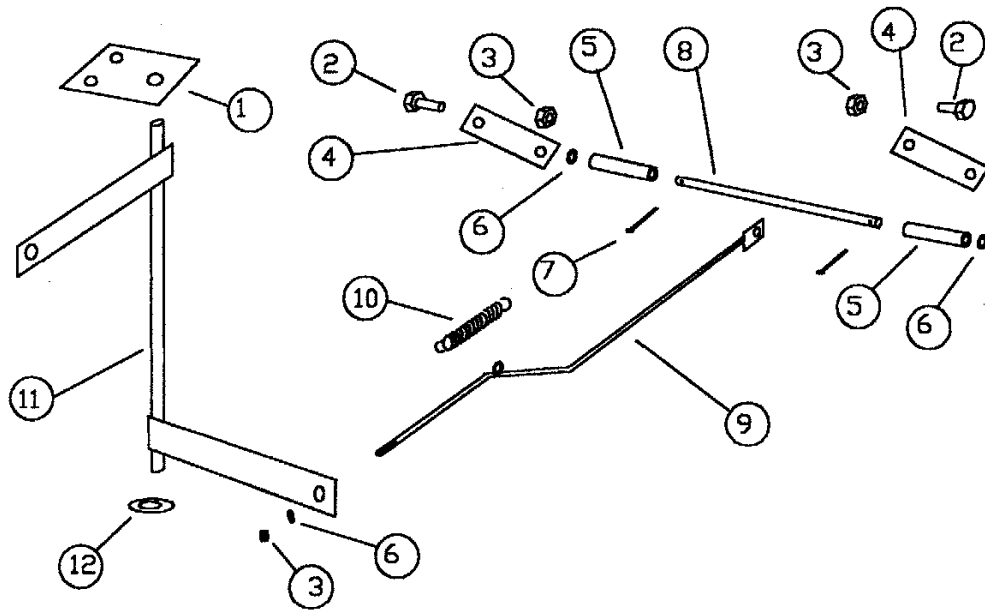

Item No	Part No	Part Description	Item No	Part No	Part Description
1	1082	Top plate, handbrake pivot	10	1352	Tension spring
2	1017	Bolt M8 x 20	11	1345	Handbrake lever assembly
3	1099	Nyloc nut M8	12	1015	Washer 1/2"
4	1029	Hydro lever, handbrake			
5	1030	Roller tube			
6	1019	Washer 8 x 20			
7	1350	Split pin			
8	1031	Handbrake tie rod			
9	1028	Rod assembly, handbrake			

ENGINE and REAR WHEEL DRIVE

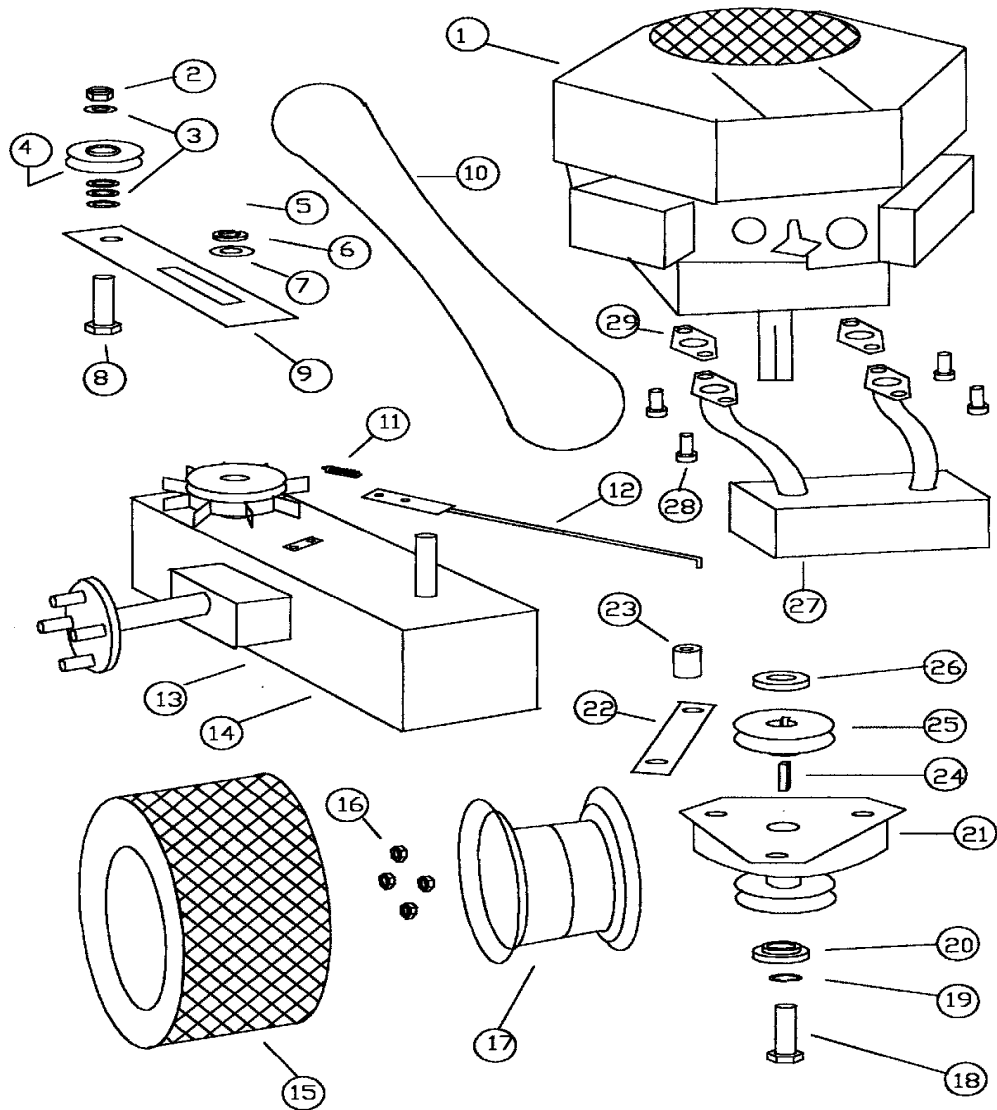

Item No	Part No	Part Description	Item No	Part No	Part Description
1	1331	Engine, B&S	16	1341	Wheel nuts
1A	1386	Engine, Honda	17	1383	Rear wheel rim
2	1016	Nyloc nut M12	18	1339	Crankshaft bolt 3/8" x 3" UNF
3	1015	Washer 1/2" x 1"	19	1060	Spring washer 3/8"
4	1014	Idler pulley 1/2" x 3" (was T618)	20	1338	Stepped collar
5	1017	Bolt M8 x 20	21	1333	Clutch
6	1018	Spring washer 8mm	22	1270	Clutch strap
7	1019	Plain washer 8 x 20	23	1271	Clutch strap spacer
8	1013	Bolt M12 x 45	24	1335	1/4" key x 29
9	1011	Idler arm	25	1336	Pulley 4"
10	1272	Drive belt	26	1337	Collar, crankshaft top
11	1024	Spring	27	1400	Muffler B&S
12	1020	Latch assembly	27A	1380	Muffler Honda
13	1267	Hydrogear transmission, LH	28	1384	Cap screw 5/16"x20 UNC
14	1268	Hydrogear transmission, RH	29	1381	Muffler gasket
15	1340	Rear tyre 20"			

MOWING DECK ASSEMBLY

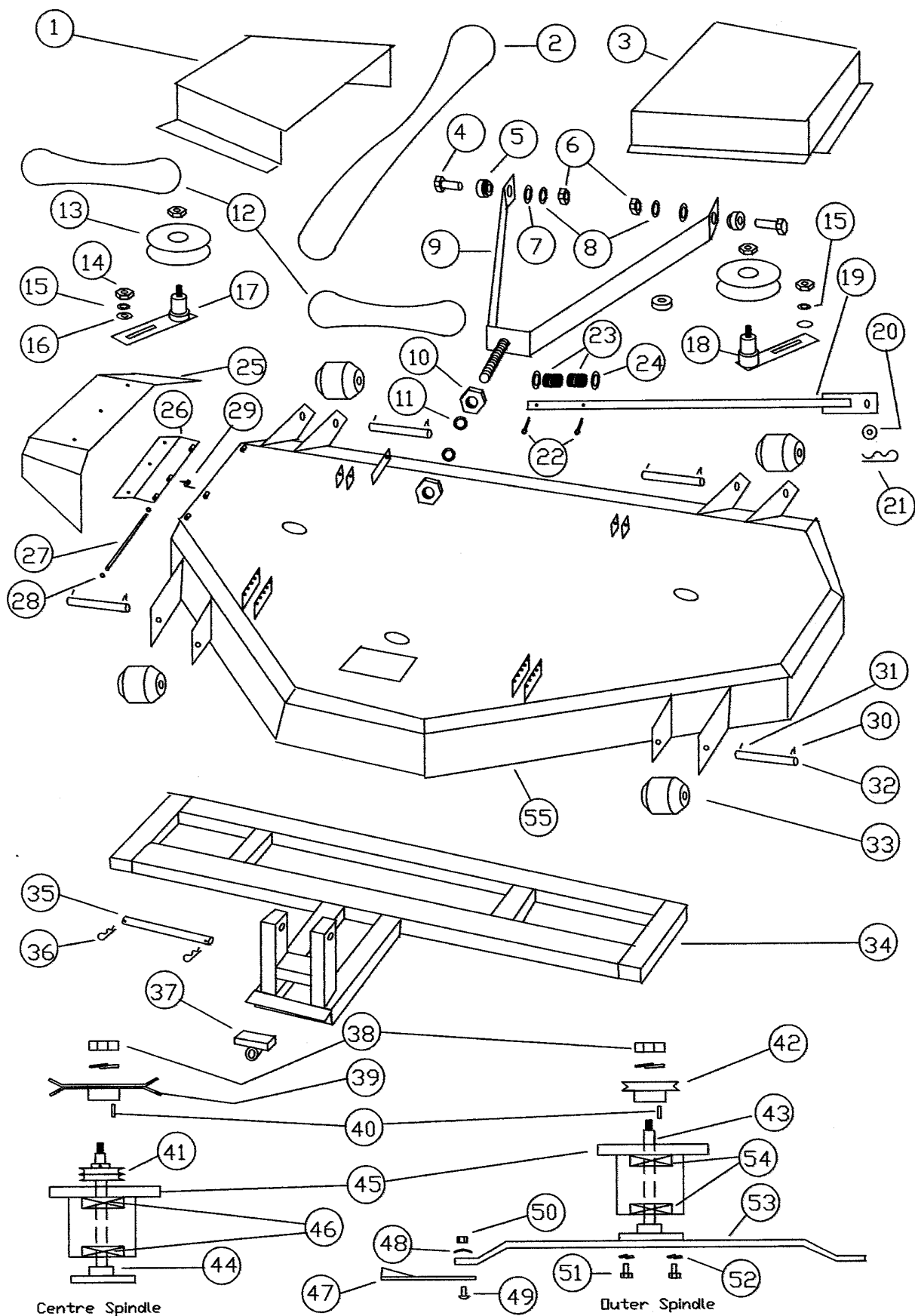

Mowing Deck Parts List

Item No	Part No	Part Description	Item No	Part No	Part Description
1	1228	Belt cover RH	30	1105	Roll pin 3mm x 20
2	1274	V belt, deck drive	31	1314	Split pin 3mm x 25
3	1227	Belt cover LH	32	1282	Axle, deck roller
4	1316	Bolt ½" x 3" HT UNF	33	1279	Deck roller
5	1046	V frame pivot bush	34	1211	Deck frame – <i>Welded to item 55 on later models.</i>
6	1049	Nut, ½" UNF			
7	1015	Plain washer ½"	35	1248	Deck retaining pin
8	1245	Spring washer ½"	36	1171	R clip
9	1203	V frame assembly	37	1207	V frame coupling
10	1210	Nut ¾" UNC	38	1319	Nut 1" UNF
11	1247	Spring washer ¾"	39	1325	Centre pulley assembly
12	1275	V belt, deck outer	40	1296	Key ¼" x 80
13	1014	Idler pulley 3"	41	1323	Double pulley (1 off)
14	1783	Nut 5/16" UNF	42	1320	Outer pulley, deck (2 off)
15	1018	Spring washer 8mm	43	1385	Spindle assembly, outer
16	1019	Plain washer 8mm	44	1388	Spindle assembly. Centre
17	1241	Blade belt tensioner (Left hand)	45	1294	Spindle housing
18	1243	Blade belt tensioner (Right)	46	1406	Centre spindle bearing (6206)
19	1233	Sway brace	47-	H651	Blades only x 2
20	1237	Washer ½" x 7/8"	50	H650	Blade, bolt, nut, washer x 2
21	1171	R clip		H652	Bolt, nut, washer set x 2
22	1239	Split pin (3/16" x 1")	51	G36	Disc retaining bolt
23	1094	Spring, sway brace	52	1060	Spring washer 3/8"
24	1238	Washer ½" x 1" x 1/8"	53	R32	Blade plate assembly
25	1000	Plastic discharge chute	54	1299	Outer spindle bearing (6305-2NSE)
26	1286	Hinge plate assembly			
27	1292	Hinge pin – flap	55	1382	Deck welded assembly
28	1291	Star lock clip, 8mm			
29	1273	Flap spring			

Rear Discharge Version - Components

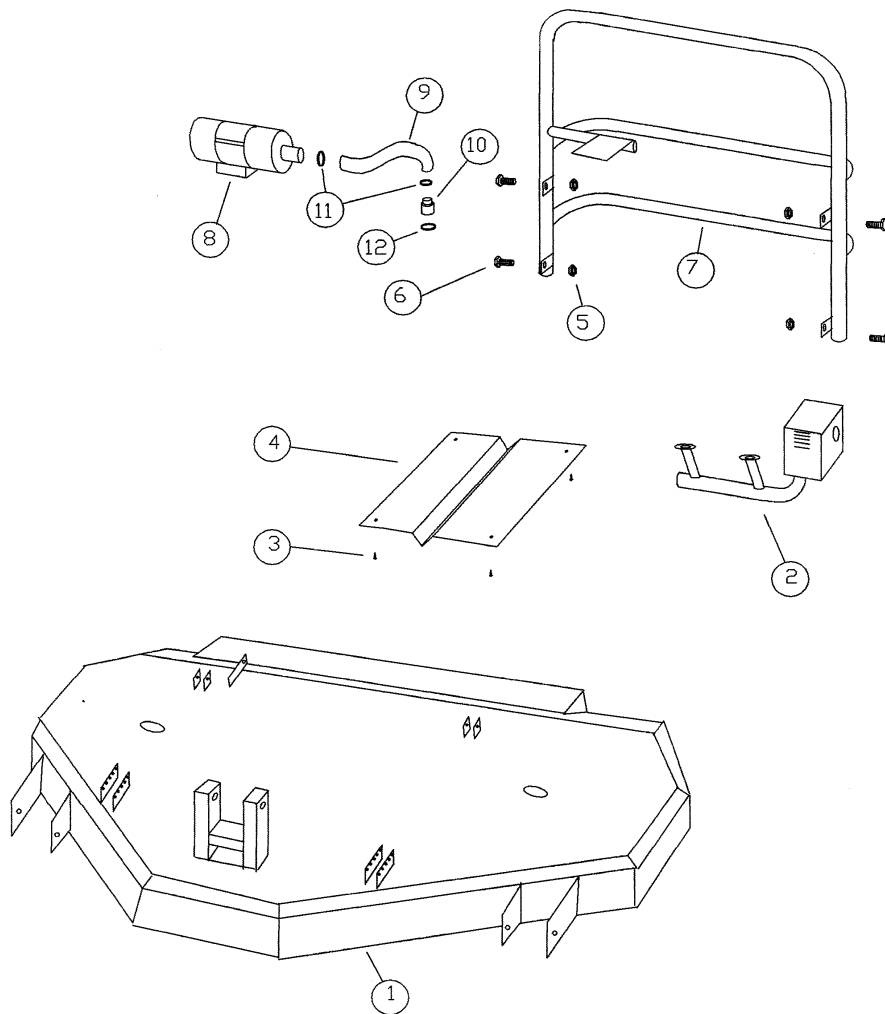

Item	Part No	Part Description
1	1769	Rear discharge deck assembly.
2	1957	Honda muffler VSM3
3	1762	Self threading screw
4	1775	Chassis plate
5	1062	Nut, nyloc, 3/8"
6	1058	Bolt, 3/8" x 1"
7	1776	Bumper bar assembly, rear discharge.
8	1799	Air cleaner, Honda No.
9	1804	Air cleaner hose.
10	1785	Air intake extension - adaptor
11	1791	Hose Clamp 25 - 40 mm (2off)
12	1792	Hose clamp 40-60 mm (1 off)